

65W/12V Desktop Power Adapter(AC/DC)

(GWS-AP65-12)



FEATURE

- Power Input: AC90~264V or 100~240VAC
- Support protection for short circuit/over current/over voltage
- Wide operating ambient temp (-20°C~65°C)
- 100% full load aging test
- High efficiency, long life time and high reliability
- No fan, completely tranquil work
- 3 years warranty



TECHNICAL SPECIFICATION

Model	GWS-AP65-12
Output	
Group Of Output	1
DC Voltage	12VDC
Output Voltage	5.5A
Ripple Noise: 0<Ta≤55°C	≤50mVp-p
Ripple Noise: -15≤Ta≤0°C	≤100mVp-p
Stabilized Voltage Precision	±1%
Line Regulation	±1%
Load Regulation	±1%

Temperature Coefficient	±0.03%/°C
Output Start Time	≤3.0S (120Vac input, Full load), ≤2.0S (220Vac input, Full load)
Output Hold Time	≥10mS(120Vac input, Full load), ≥20mS(220Vac input, Full load)
Voltage Overshoot	<5.0%
Input	
Input Voltage Range	90VAC-264VAC or 100-240VAC (custom)
Input Rated Voltage Range	100VAC-240VAC or 100-240VAC (custom)
Frequency Range	47Hz-63Hz or 50Hz-60Hz (custom)
Efficiency	85%
Input Current	<0.7A
Inrush Starting Current	<40A@300Vac Cold start
Leakage Current	input to output less than 0.25mA
Protection	
Output Over Power	54~97.5W Swing machine (Testing method: Increase the output current until enabling the protection. Protection mode:Swing machine, Self-recovery after over-power released.)
Output Over Voltage	15-10V Swing machine (Short circuit the Pin1-2 of U8, swing machine. Output recovery to normal after removing the short circuit) Note: Do not use external voltage.
Output Over Current	6.5~8.8A Swing machine (Testing method: Increase the output current until enabling the protection. Protection mode:Swing machine, Self-recovery after over-current released.)
Output Short Circuit	It can be short circuited for a long time and automatically recover after the short circuit is eliminated.
Operation Environment	
Operation TEMP / Humidity	-20°C~65°C, 20%~90%RH No condensing
Storage TEMP / Humidity	-40°C~85°C, 5%~95%RH No condensing
Safety And EMC Standard	
Security Standard	GB4943/ EN62368-1
Dielectric Strength	Input—Output:3KVac/10mA, Input--Case:1.5KVac/10mA, Output---Case:0.5KVDC/10mA , Time for each testing is 1min.
Insulation Resistance	Input-Output: 100M ohms, Input-Case: 100M ohms Output-Case: 100M ohms
Electromagnetic Interference	EN55022 Class A
Harmonic Current	IEC61000-3-2 class A equipment requirements
Electromagnetic interference Immunity	EN61000-4-2,4,5,6,8,11 ENV50204, class A heavy industry standard
Others	

Design MTBF	100,000Hrs AT 25°C, MIL-217 Method 2 Components Stress Method
Product size(L*W*H)	125*51*32mm
Notes	<p>If the specification is not specified, all specifications and parameters shall be measured at rated input, rated load and 25 C ambient temperature.</p> <p>Ripple noise test method: the use of a 12# twisted pair, while the terminal to parallel capacitance of 0.1uF and 10uF, measured at the scope of the oscilloscope 20MHz bandwidth.</p> <p>The power supply will be installed on the final equipment as a component, and the final equipment will still have to meet the EMC condition.</p> <p>Plugin Standard EU.</p>

DIMENSION

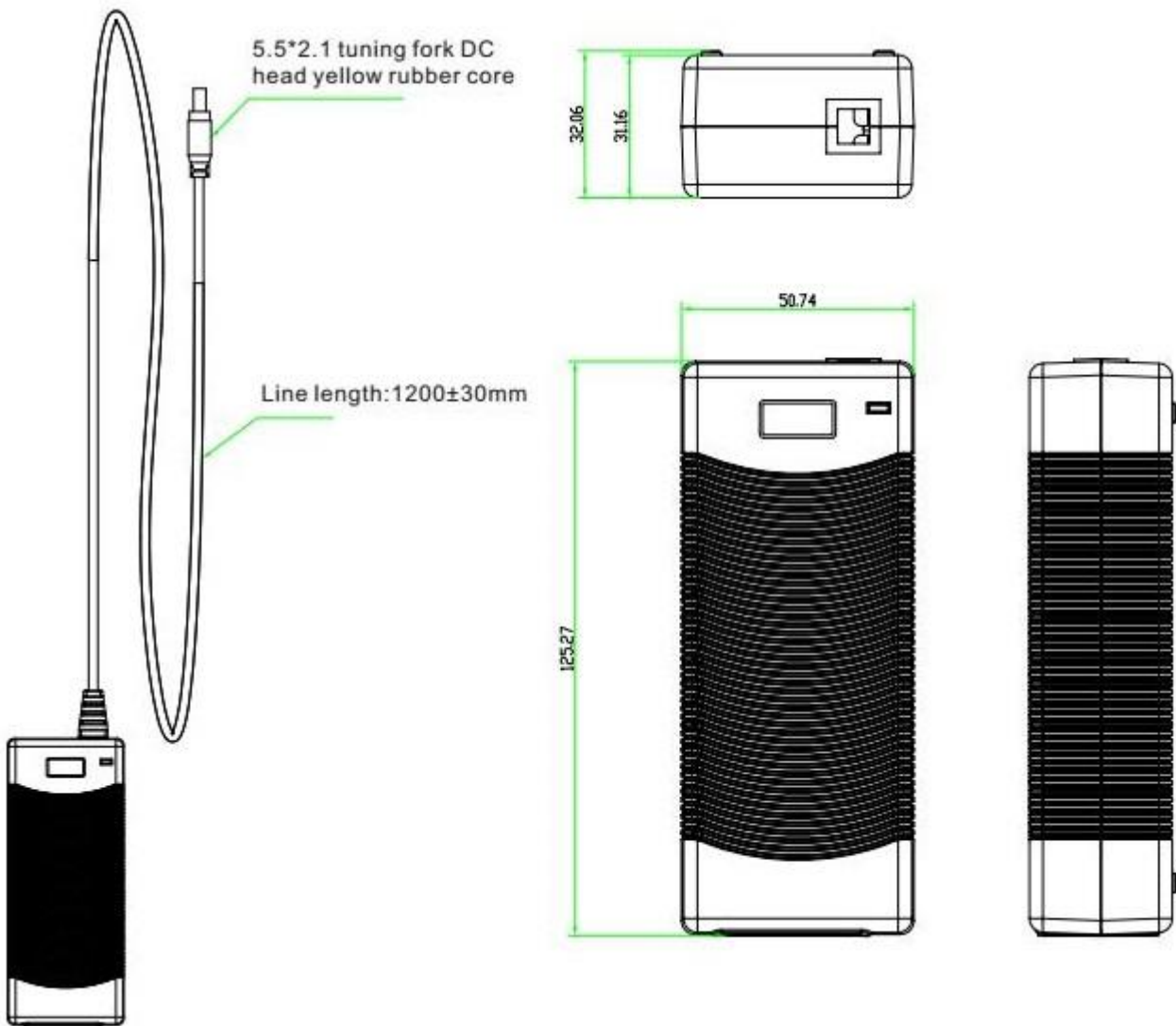

BLOCK DIAGRAM

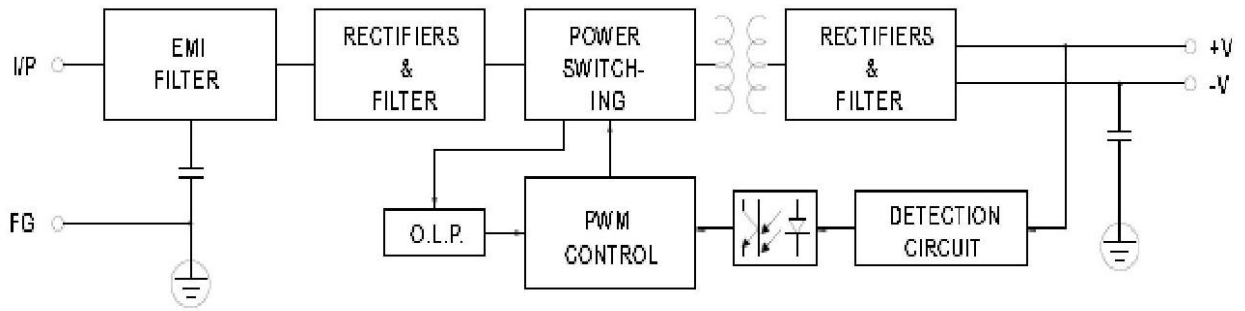

Derating Curve

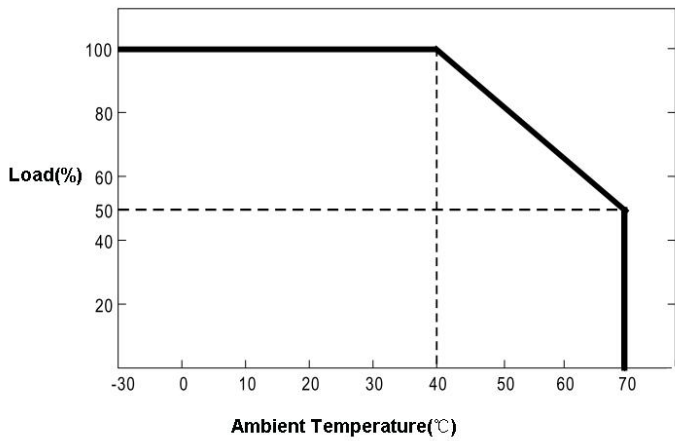

Static Characteristic Curve

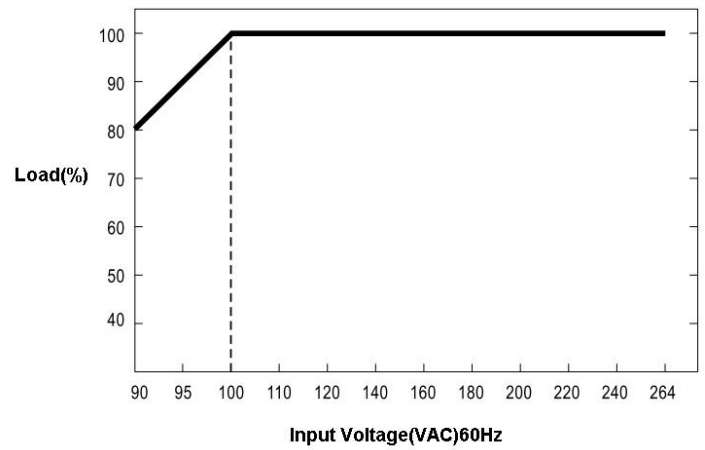

CONTACT US



Tel: 0086-755-33376606

Fax: 0086-755-33376608

Email: onv@onv.com.cn

Website: www.gwsdz.com

Zip: 518000

Headquarter Address: Room 1003, Block D, Terra Building, Futian District, Shenzhen, China

Factory Address: The 4-6th Floor, A building, Senyutai (Science&Technology) Park, Huaning Road, Dalang Street, Longhua District, Shenzhen, China